

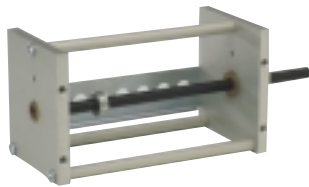

Miniature Sequence Programmer

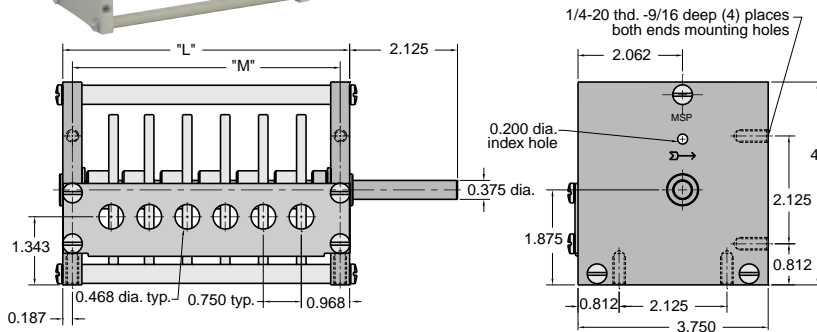

Center Shaft Replaceable Cam
Miniature Sequence Programmer



Use: ** Power may be by machine controlled or by any small geared-down motor. Cams mounted on shaft operate up to 14 Clippard standard 2-, 3-, or 4-way valves (using Cam Follower 11925), and snap action switches such as Clippard ES-1. Valves on unit may control large pilot operated valves, or may be connected directly to cylinders, air limits, or circuitry, eliminating costly switches and solenoid valves.
** Cams not included

Furnished with valve mounting bracket and Allen wrench. May be used with standard, adjustable or special cut cams at extra charge. Please specify desired cams when ordering. Use Clippard wrench #11751 for valve mounting.

Recommended Torque: Approx. 2 in. lbs. per cam.

Timing: Cams aligned originally using rod through holes in end blocks and cams. Once locked to shaft, timing is permanently established, rotation of cams actuates valves according to lobes provided. (see cam data)

Construction Features:

- Self-lubricating bronze bearings
- 1/8" black oxidized steel shaft-extendible either end
- One-piece phenolic cams - extendible either end
- Easy cam adjustment - one set screw
- End plates tapped for mounting bottom or rear
- Positive cam indexing
- Heavy aluminum end blocks
- Rigid channel steel mounting bracket for valves, switches

Part No.	# of Cams	"L"	"M"
MSP-4	.4	.4.156	.3.781
MSP-6	.6	.5.656	.5.281
MSP-8	.8	.7.156	.6.781
MSP-10	.10	.8.656	.8.281
MSP-12	.12	.10.156	.9.781
MSP-14	.14	.11.656	.11.281

Miniature Sequence Programmer



Center Shaft Replaceable Cam Detent
Sequence Programmer.

Specify desired standard Clippard programmer cams plus one detent cam.

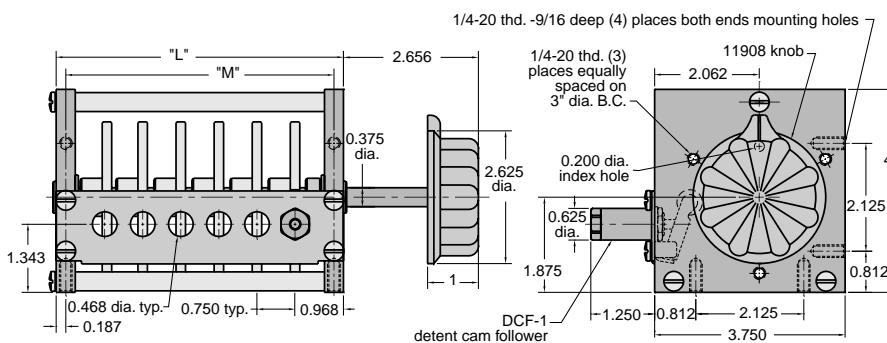

Construction: Basically the same as the MSP programmers with the addition of a spring plunger detent mechanism, an extended shaft with hand knob, and tapped mounting holes for panel mounting

No. Of Cams*: 3 to 13, depending upon model; six standard models (3, 5, 7, 9, 11 and 13 valve stations respectively)

Mounting: Mount on panel, or by bottom or rear, as required; three (3) 1/4-20 tapped holes provided on front plate for flush mount to panel; additional holes provided on front plate for flush mount to panel; additional holes at bottom and sides of end plates

*Cams not included

Use: Manually to set a predetermined sequence; or as a stepping switch

Part No.	# of Cams	"L"	"M"
DSP-3	.3	.4 5/32	.3 25/32
DSP-5	.5	.5 21/32	.5 9/32
DSP-7	.8	.7 5/32	.6 25/32
DSP-9	.9	.8 21/32	.8 9/32
DSP-11	.11	.10 5/32	.9 25/32
DSP-13	.13	.11 21/32	.11 9/32